

## 80W LED CORN BULB—for 250W HPS/MH/HID replacement



### Specifications

<b>Model</b>	E2CLS-80W
<b>Rate Power</b>	80W
<b>Input Voltage</b>	AC100-277V 50-60HZ
<b>CCT</b>	2700K-5700K
<b>Base</b>	E39
<b>Power Factor</b>	0.98
<b>CRI</b>	>80
<b>Lumen</b>	6032.9LM-6412LM
<b>Chip</b>	Samsung 5630
<b>LED Qty</b>	234pcs x 0.3W
<b>Certification</b>	UL, DLC, Lighting Fact, LM79
<b>Lifespan</b>	50,000hrs
<b>Warranty</b>	5 years for TOTAL product



Samsung LM561B



Rubycon



E39



JAE Connector

### Dimension

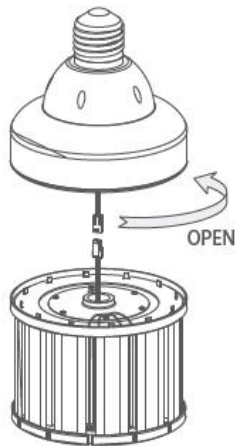
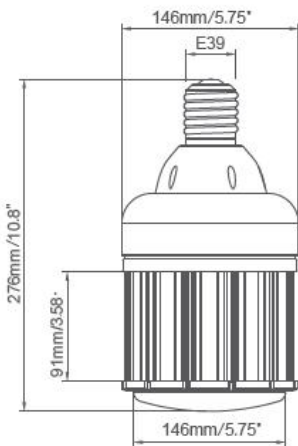

### Luminous emittance

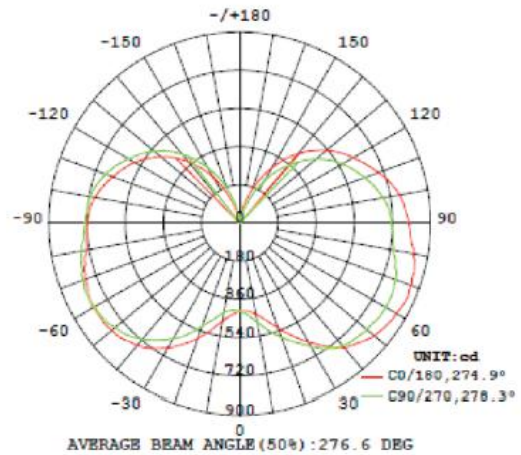

Long Lifespan of 10years



Reliability Test

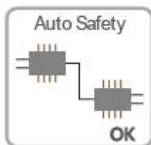

Safety Protection Circuit



No Mercury  
No UV Light



Big Saving (87%)  
on Electricity Costs



Usable in Enclosed  
Luminaires



Omni Wide Angle

## Installation

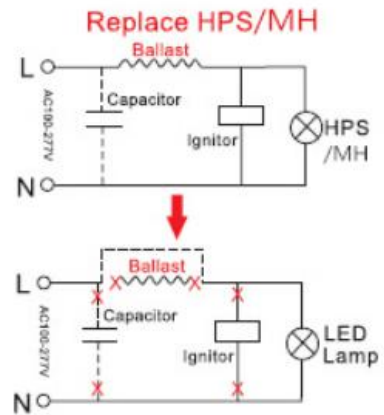
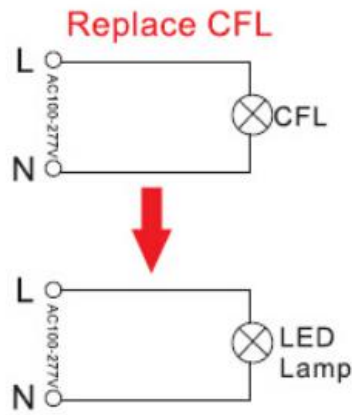

## Absolute Maximum Rating

Aluminum Heat Sink Temperature	65°C
Operating Temperature	-20~+50°C
Storage Temperature	-40~+80°C
Equilibrium Temperature	25°C

## Product Packing Specification

Pack Quantity	4pcs	
Net Weight	1735g	
Gross Weight Per CTN	8.62kg	
Box Size	185*185*307mm	
CTN Size	385*385*327mm	

## CAUTIONS

- Make sure remove the traditional ballast before replace the LED corn light.
- Don't take apart the product or replace mechanical and electronic components.
- Don't stare at the strong light for a long time as it may cause injury to eyes.